

Catio- Cat Hous Plan

8×10

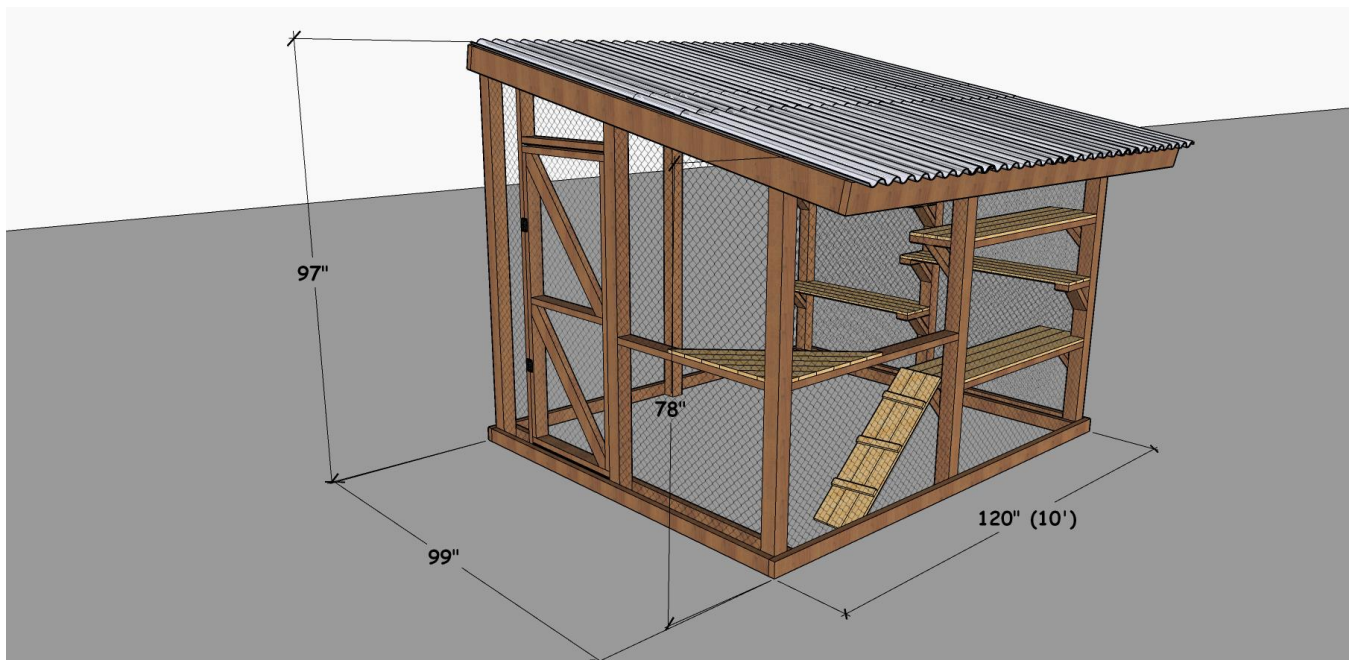
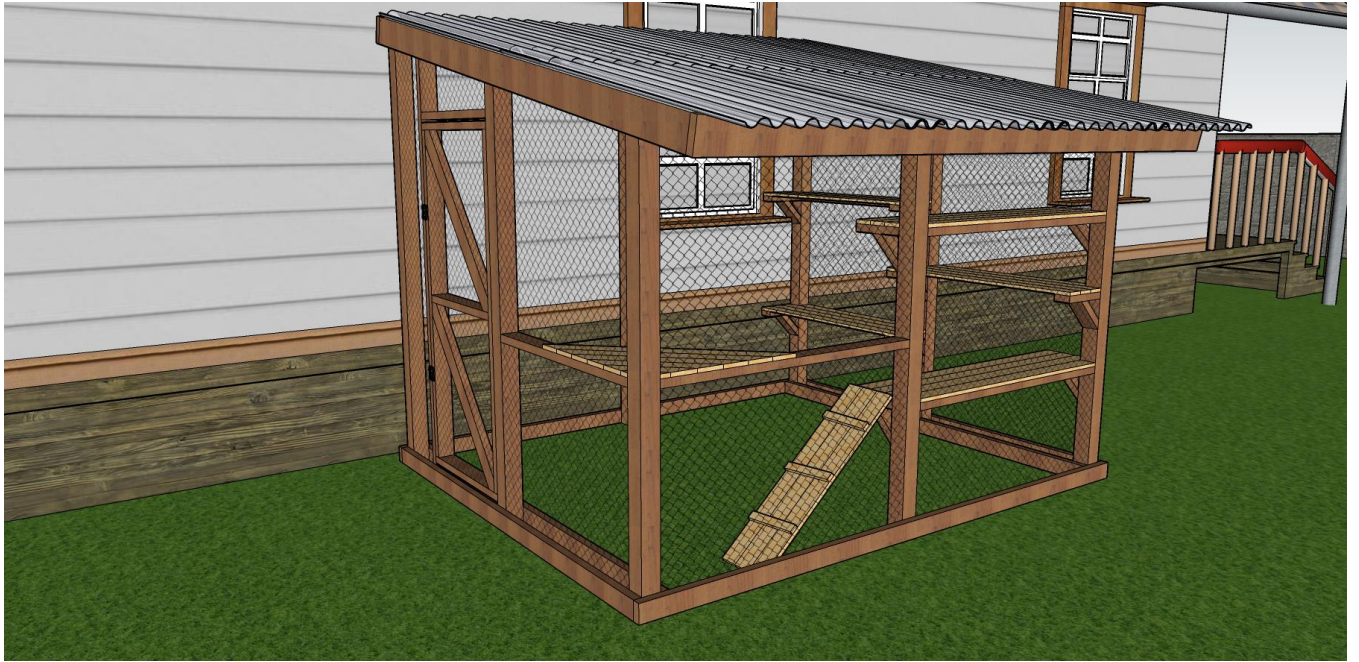

INSTRUCTIONS

Always use straight boards. Check for square after each step. Always predrill holes before attaching with screws.

Please read entire manual before

you must use rot-resistant lumber such as Redwood or Cedar. Because cedar and redwood both are long-lasting and durable. The correct selection of the lumber is crucial otherwise all your hard work will be wasted.

when buying the lumber, you should select the planks with great care, making sure they are straight and without any visible flaws (cracks, knots, twists, decay).

TOOLS

Safety Gloves, Glasses

Miter Saw, Jigsaw, ladder

Tape Measure, Spirit level, Carpentry Pencil

Drill Machinery and Drill Bits

SHOPPING LIST

MATERIAL	DIMENSION	QTY
2×4 LUMBER	8 ft	16
2×4 LUMBER	10ft	2
2×6 LUMBER	10ft	10
4×4 LUMBER	8ft	8
1×4 BOARD	8 ft	16
SCREWS	3 1/2"	150
SCREWS	2 1/2"	150
SCREWS	1 1/2"	100
POLYCARBONATE PLASTIC ROOF PANEL	3ft × 6ft	8
HINGES	2-1/2 in.	2
HARDWARE CLOTH	36" × 100'	1

CUT LIST

Start cutting the pieces.

	<u>Material</u>	<u>Dimension</u>	<u>Qty</u>
Step 2	4×4 lumber	87"	2
Step 2-3-6-15	4×4 lumber	78"	3
Step 3	2×4 lumber	93"	1
Step 4-7-8	2×4 lumber	30"	3
Step 4	2×4 lumber	42 3/4"	4
Step 5	2×4 lumber	10 1/2"	10
Step 8	2×4 lumber	53 1/4"	3
Step 16	2×4 lumber	43"	2
Step 16	2×4 lumber	68"	2
Step 16	2×4 lumber	27"	1
Step 13-14	2×4 lumber	9"	10
Step 8	2×6 lumber	113"	8
Step 3	1×4 board	49 3/4"	9
Step 9	1×4 board	42 3/4"	3
Step 9	1×4 board	60 1/4"	6
Step 9	1×4 board	53 1/4"	2
Step 9	1×4 board	42"	3
Step 9	1×4 board	42 1/2"	1
Step 9	1×4 board	35 1/2"	1
Step 9	1×4 board	28 1/2"	1
Step 9	1×4 board	21 1/2"	1
Step 9	1×4 board	14 1/2"	1

STEP 1

4 pieces of 2×4 lumber -8' full long

2 pieces of 2×4 lumber -10' full long

Start from the foundation and work your way up to the roof.

Using a speed square or carpenter's square ,check the corners to make sure they are 90°.

cut the components from 4×2 lumber at the right dimensions.drill pilot holes through the plates and insert 3 1/2" screws into the studs.

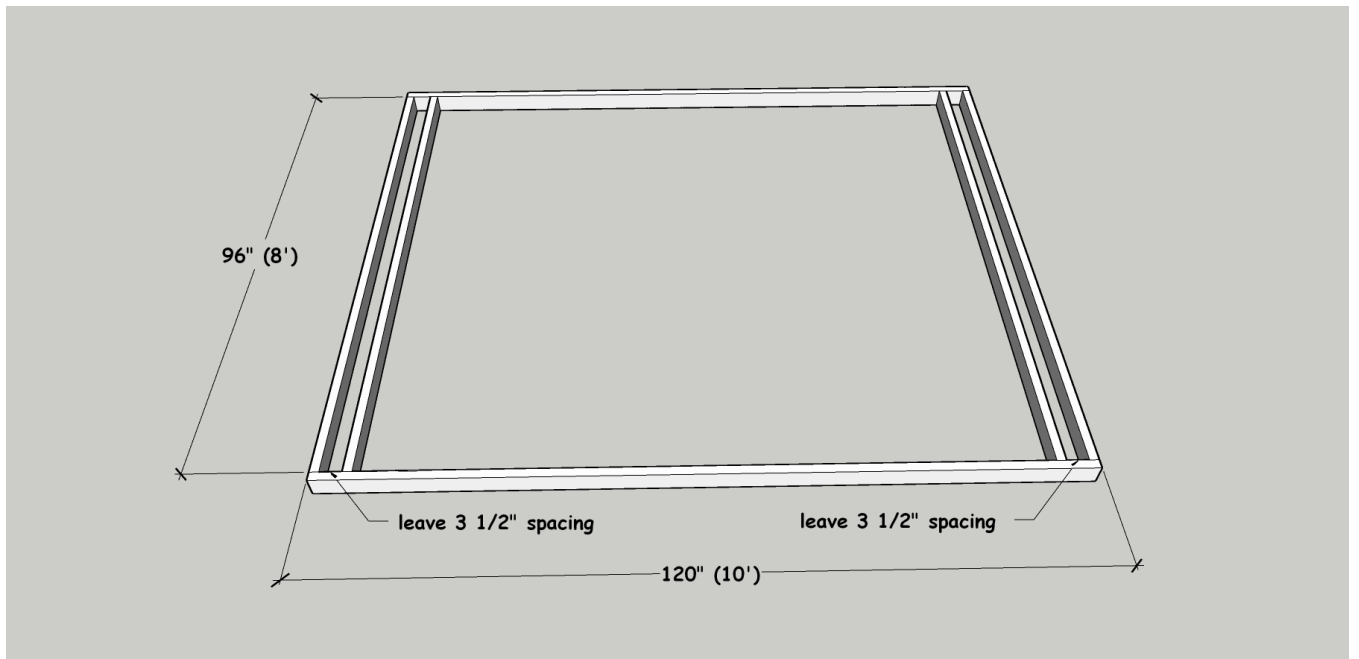

STEP 2

3 pieces of 4×4 lumber - 78" long

2 pieces of 4×4 lumber - 87"long

3 pieces of 4×4 lumber -8' full long

Using a speed square or carpenter's square ,check the corners to make sure they are 90°.

between the two posts at the entrance measures 42 3/4".

Use 3 1/2" screws. Drill pilot holes first.

STEP 4

get help from your friend for this step.

Use 3 1/2" screws

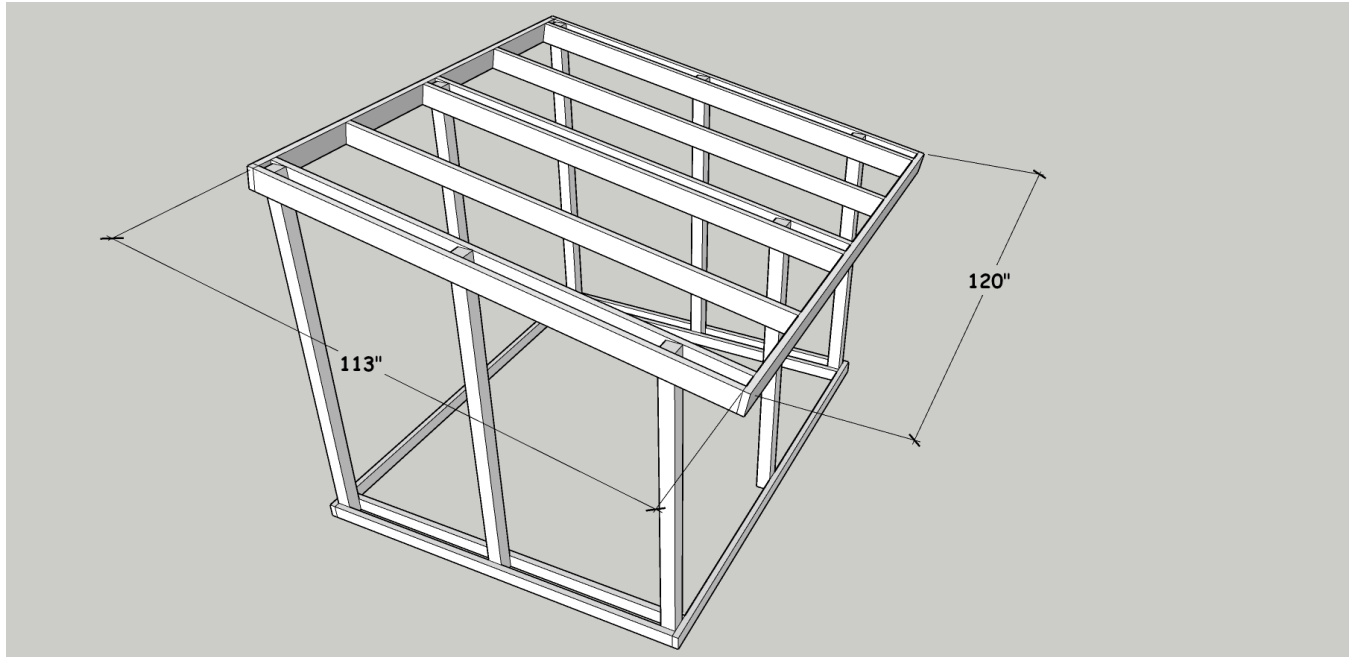

STEP 5

1 piece of 2×4 lumber - 93"long

1 piece of 2×4 lumber - 30"long

Create the door frame, using 2×4 for the door.

corners must be 90 degrees

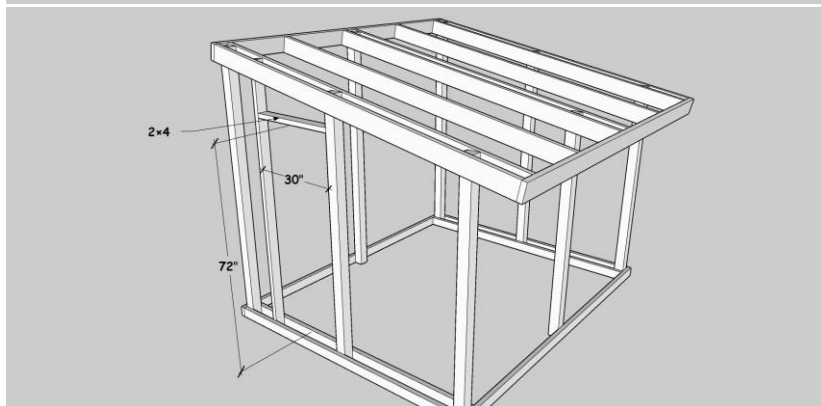
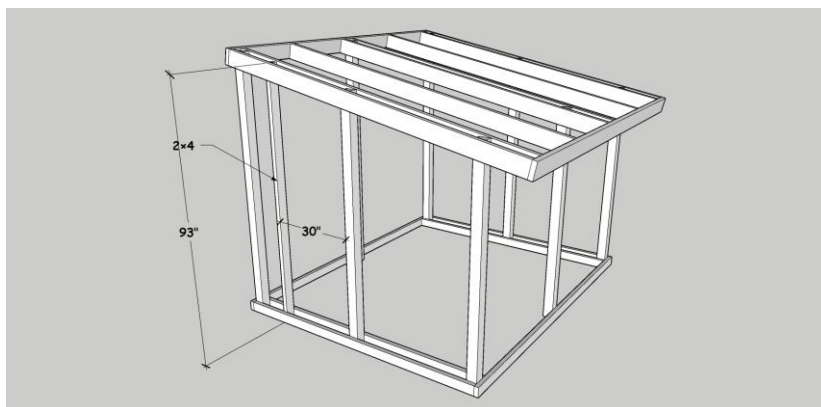

STEP 6

2 piece of 2×4 lumber – 42 3/4" long

start building shelves.

drill holes before screwing

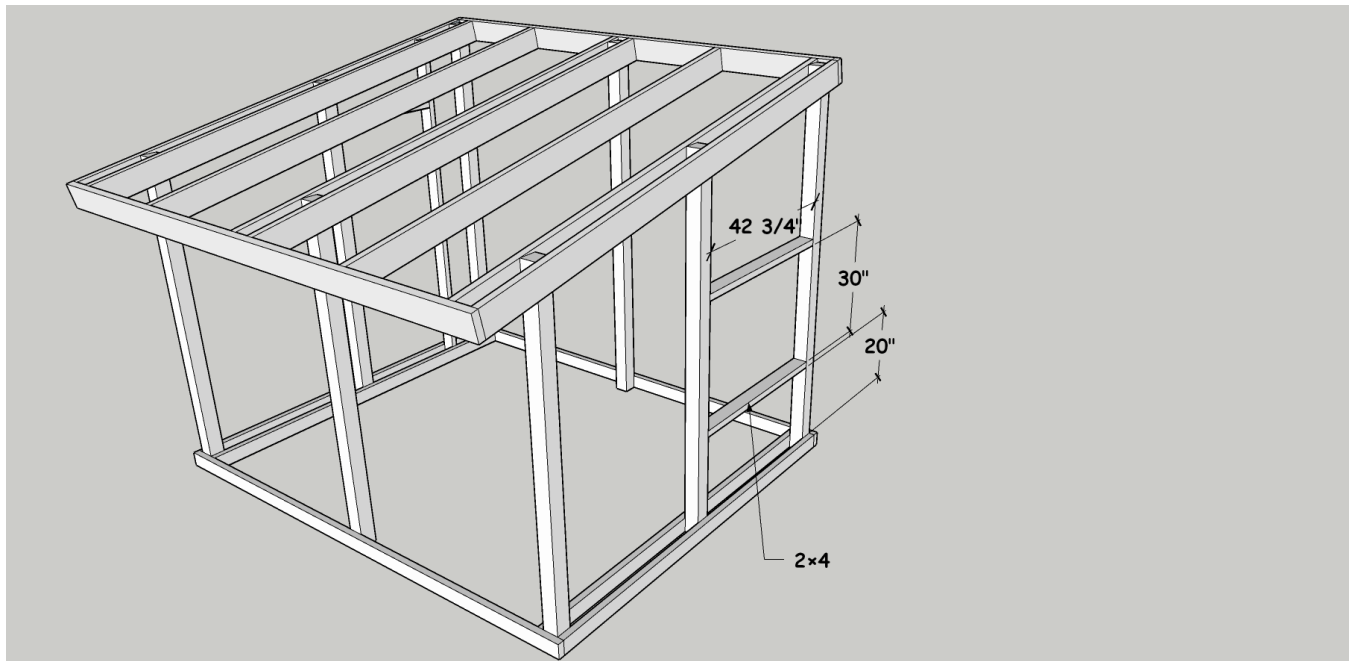

STEP 7

10 pieces of 2×4 lumber - 9" long

4 pieces of 2×4 lumber - 10 1/2" long

drill pocket holes at both ends of the 2×4 and secure them into place with 2 1/2" screws.

you'll need a total of 10 of the 2×4 in the photo.

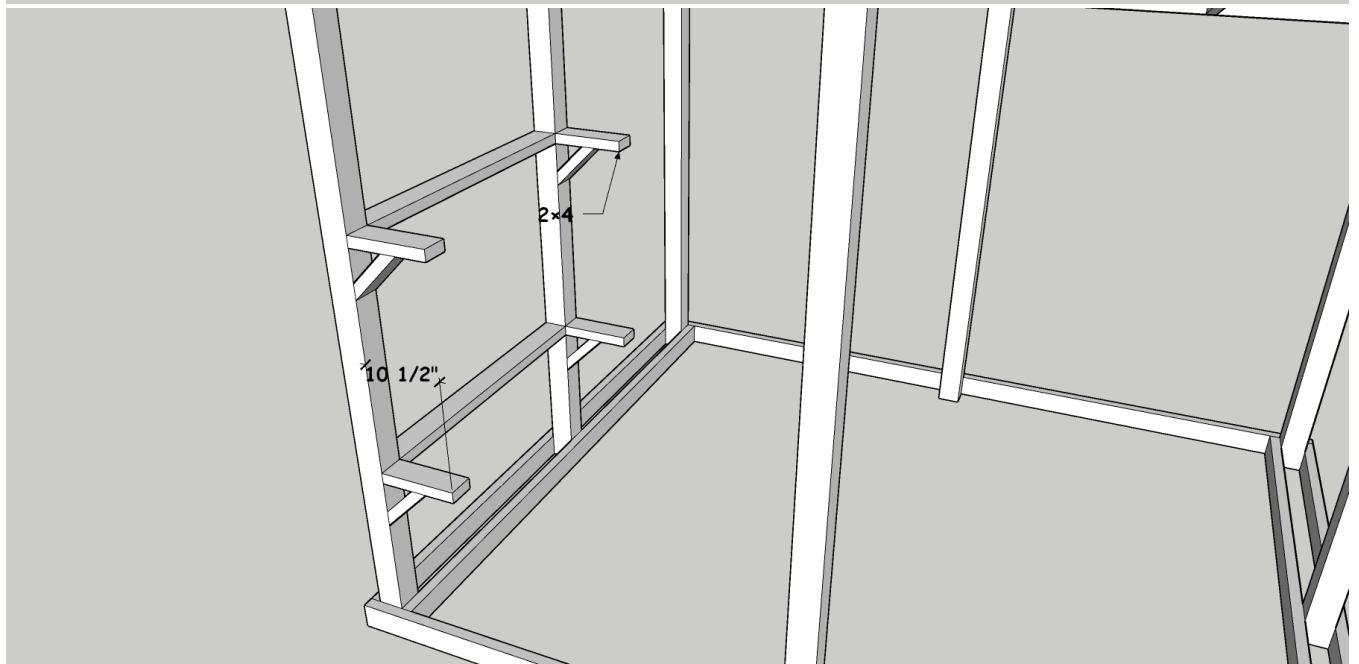
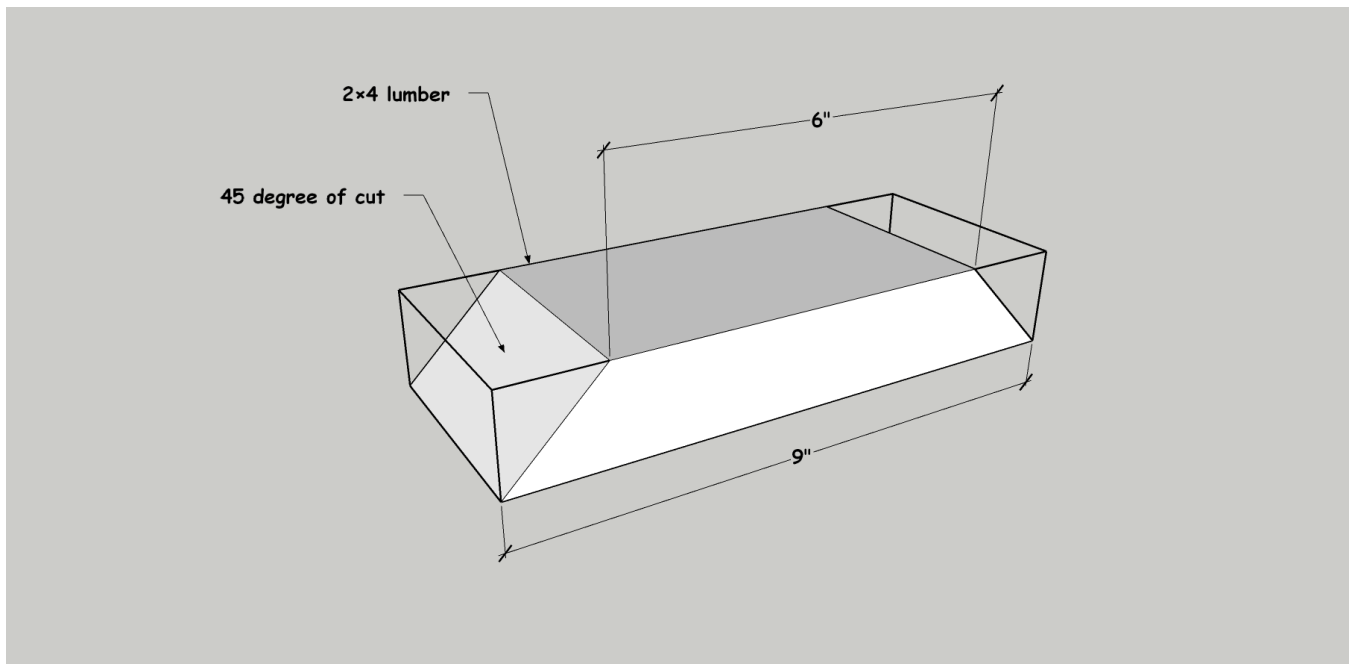

STEP 8

2 pieces of 1×4 board – 42 3/4" long

6 pieces of 1×4 board - 49 3/4" long

Fasten the 1×4 boards to the 2×4 lumber with 1 1/2" screws.

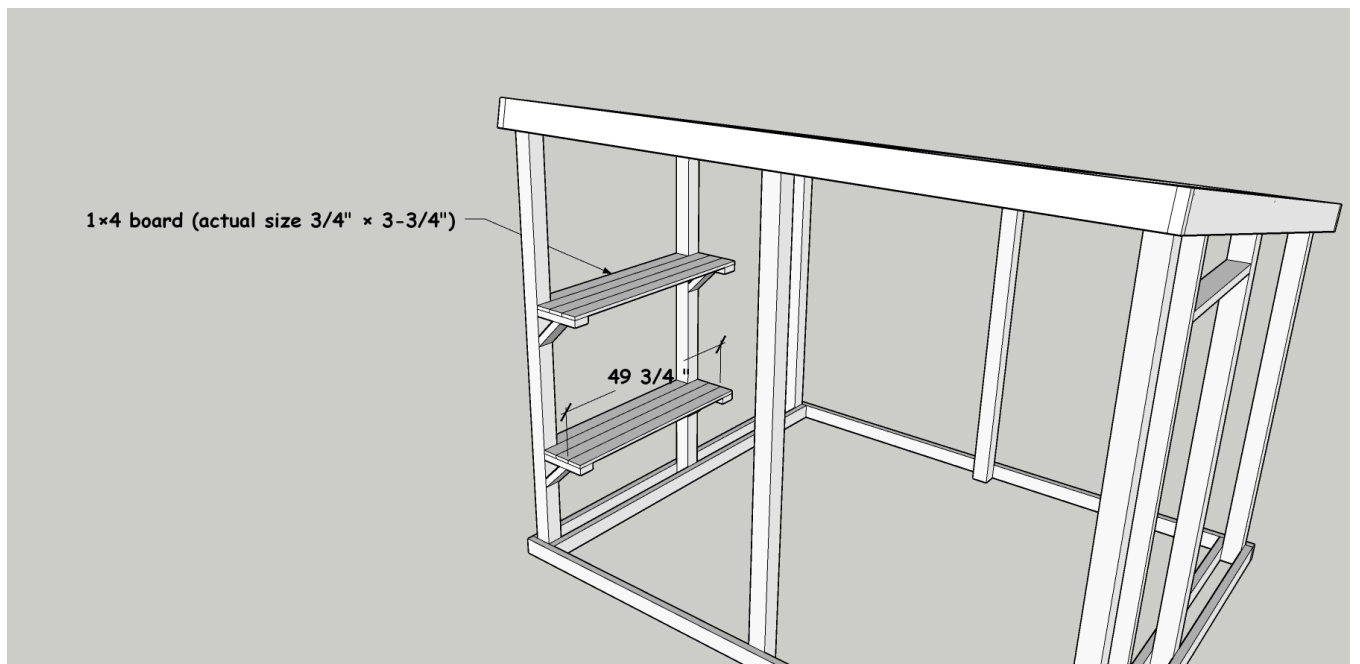

STEP 9

1 pieces of 2×4 lumber – 42 3/4" long

2 pieces of 2×4 lumber - 10 1/2" long

3 pieces of 1×4 board – 49 3/4" long

1 pieces of 1×4 board – 42 3/4" long

Screw the 4×2's as in the photo

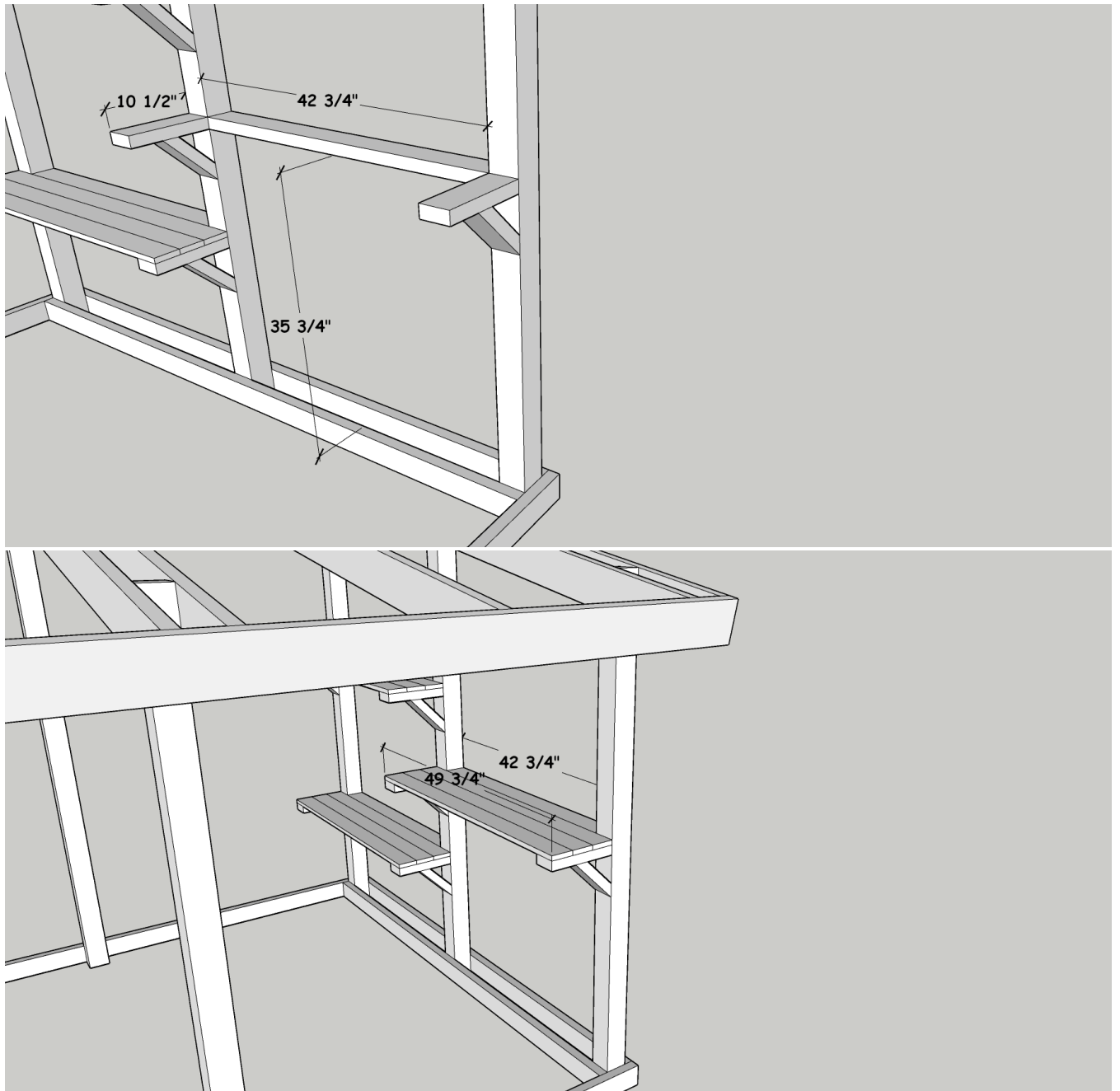

STEP 10

2 pieces of 2×4 lumber -53 1/4"long

Use 3 1/2" screws.

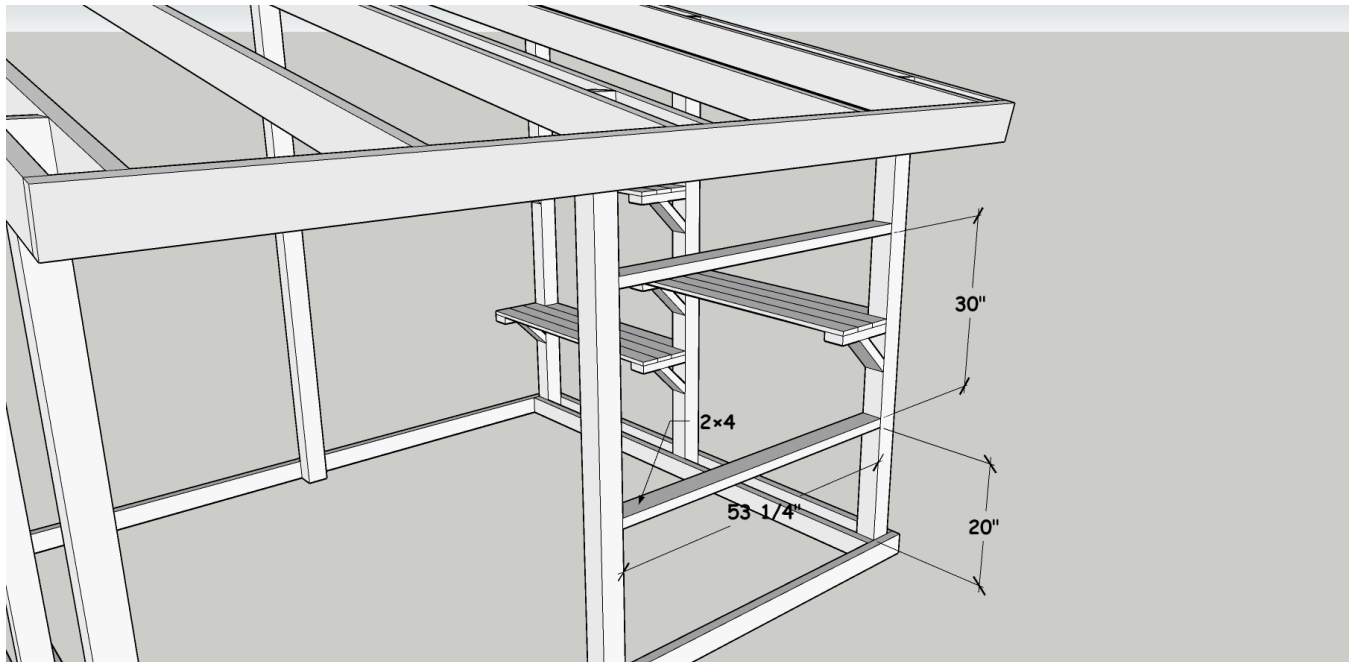

STEP 11

test for strength after screwing in

4 pieces of 2×4 lumber - 10 1/2" long

6 pieces of 1×4 board - 60 1/4" long

2 pieces of 1×4 board - 53 1/4" long

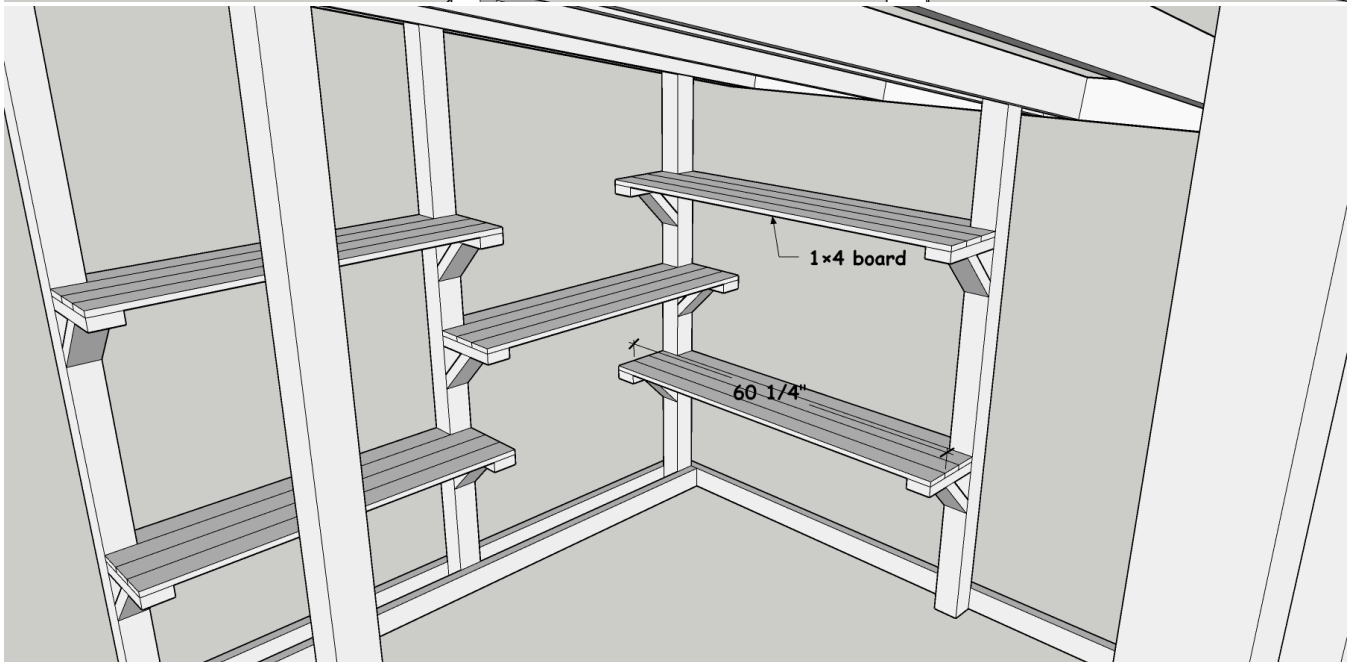
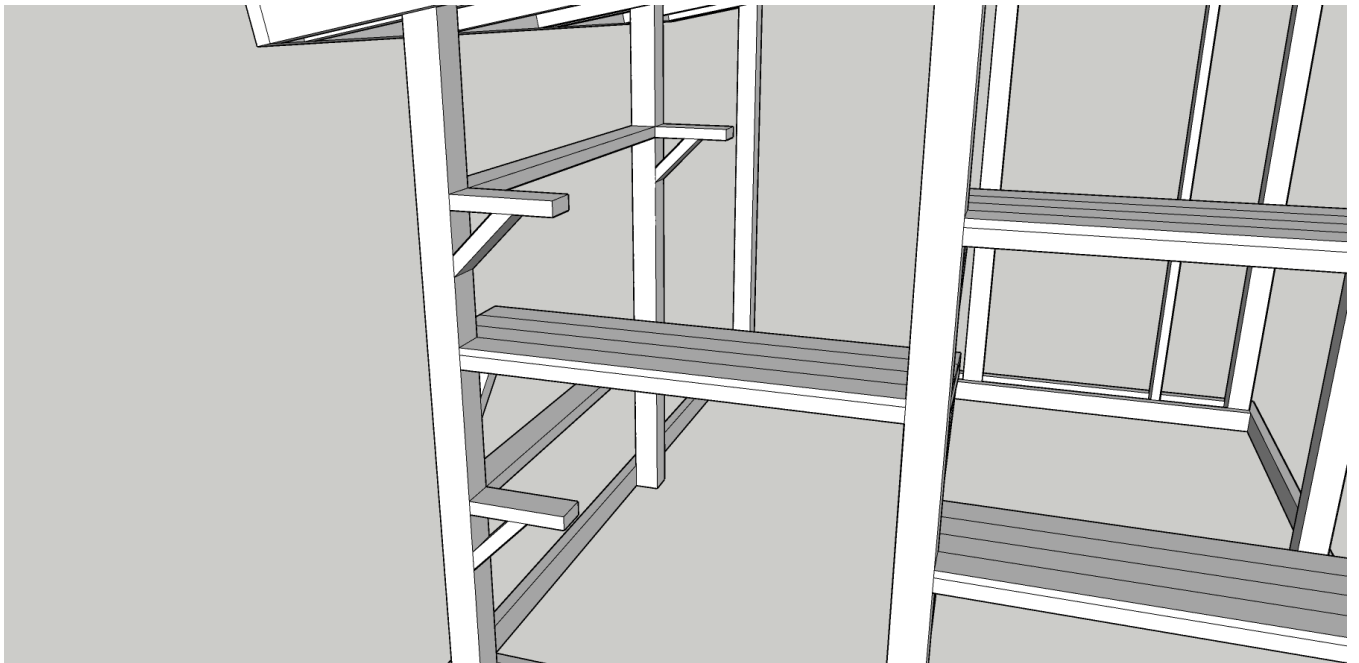

STEP 12

1 pieces of 2×4 lumber -53 1/4"long

1 pieces of 2×4 lumber -42 3/4"long

Use 3 1/2" screws

Using a speed square or carpenter's square ,check the corners to make sure they are 90°.

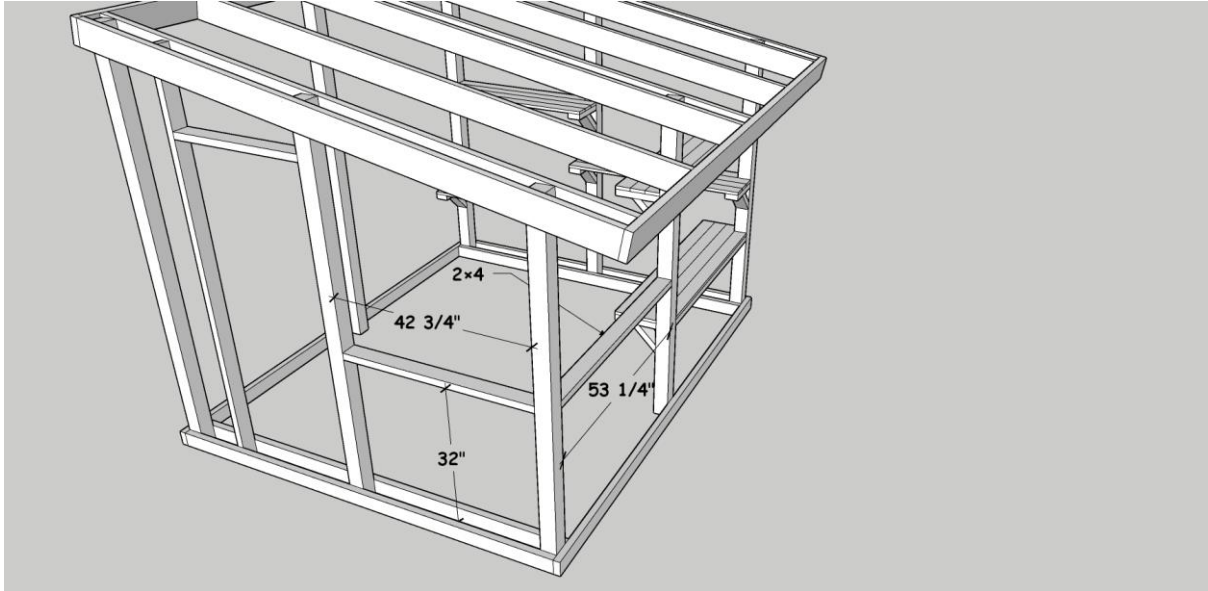

STEP 13

1 pieces of 1×4 board - 42 1/2"long 1 pieces of 1×4 board - 35 1/2"long

1 pieces of 1×4 board - 28 1/2"long 1 pieces of 1×4 board - 21 1/2"long

1 pieces of 1×4 board - 14 1/2"long

secure them into place with 1 1/2" screws

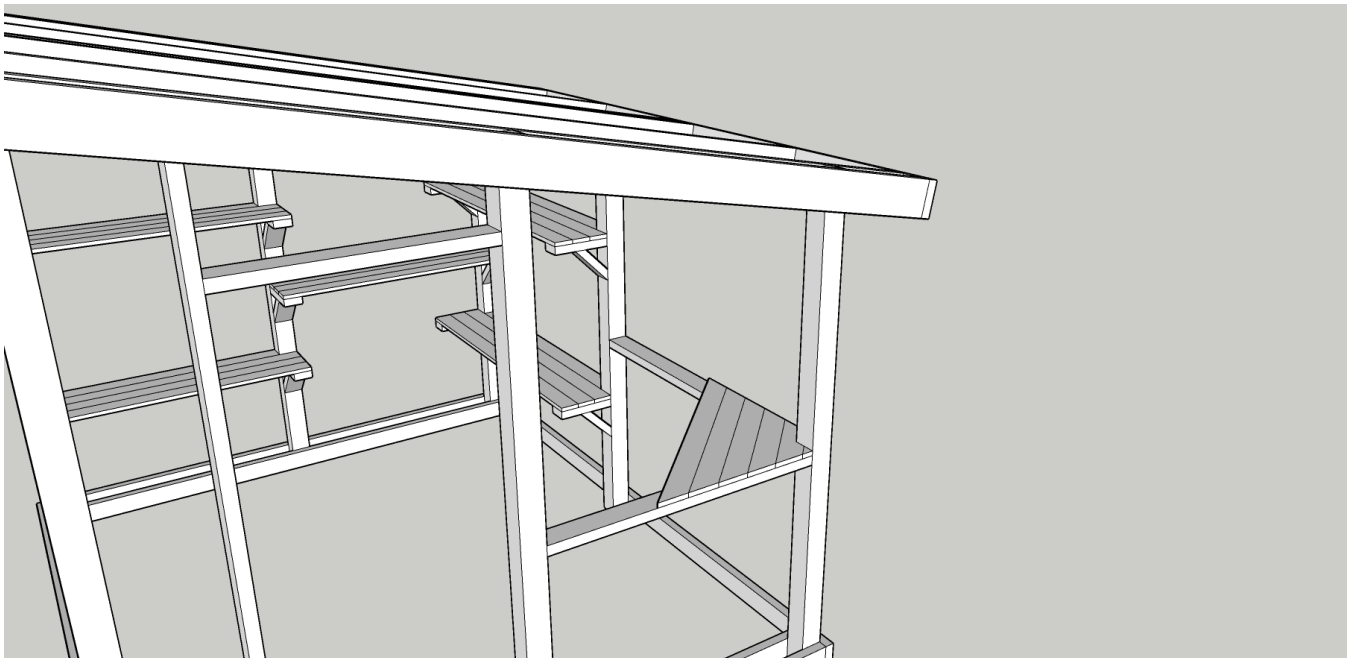

STEP 14

3 pieces of 1×4 board - 42" long

3 pieces of 1×2 board - 10 1/2" long

create a cat ramp.

Use 1 1/2" screws

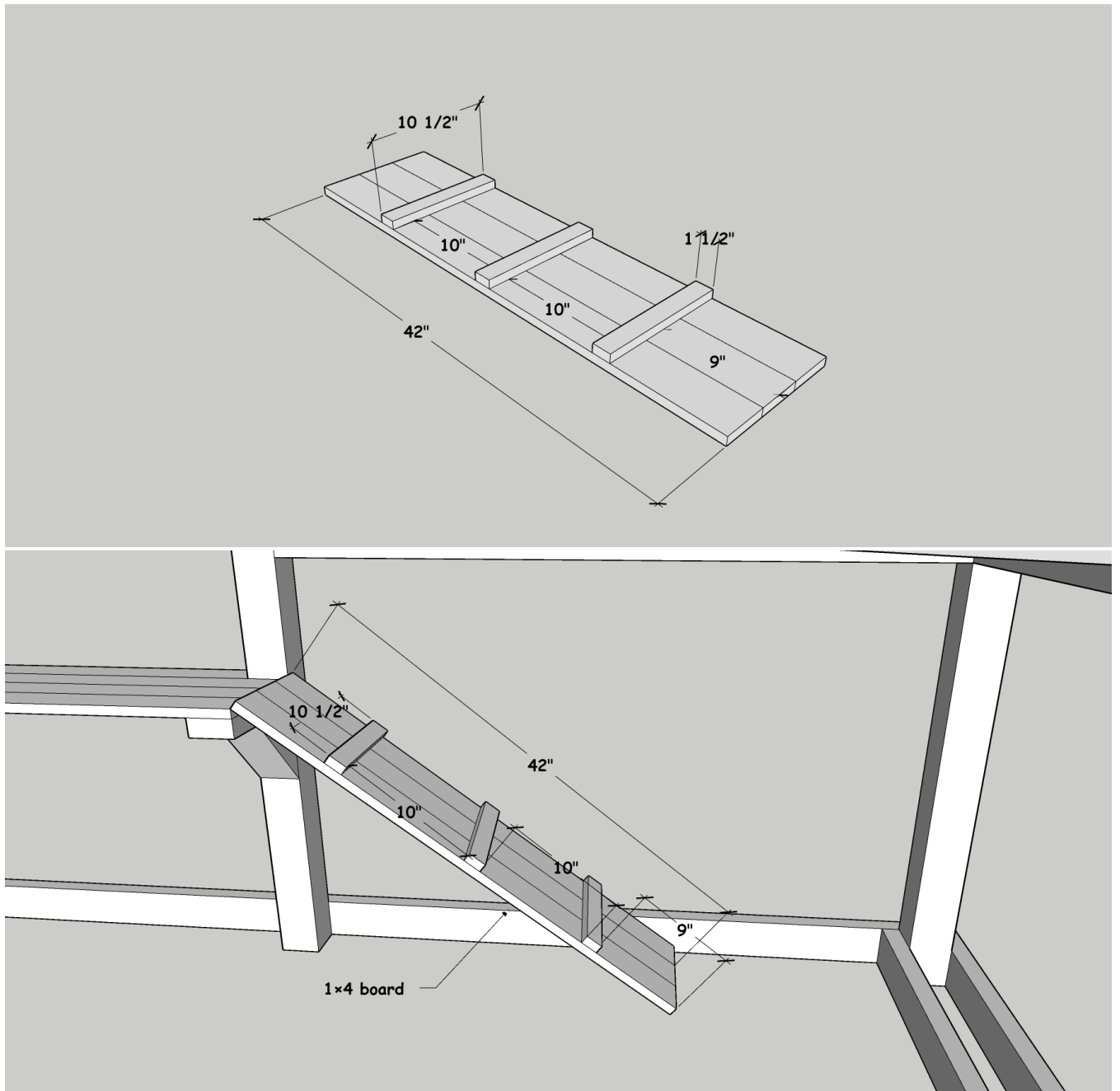

STEP 15

You will need 8 pieces of 3ft×6ft corrugated transparent polycarbonate plastic roof panels

Fit the polycarbonate sheets to the top of the catio. Align the edges and insert the appropriate screws to lock the sheets to rafters. The polycarbonate sheets will protect the catio from the elements, but in the same time it will let the light get through.

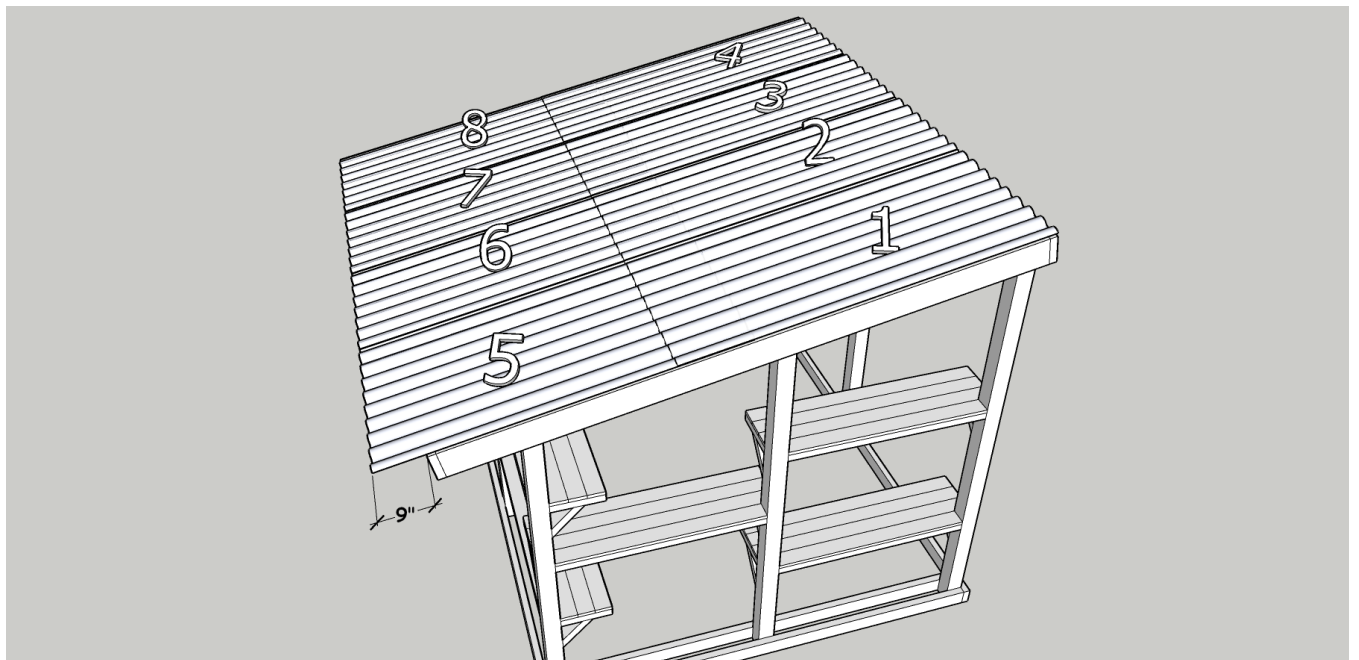

STEP 16

continue the project by fitting the hardware cloth to the exterior of the catio. Use staples to lock the mesh into place tightly. align the edges with attention and make sure, so you adjust it to fit into place.

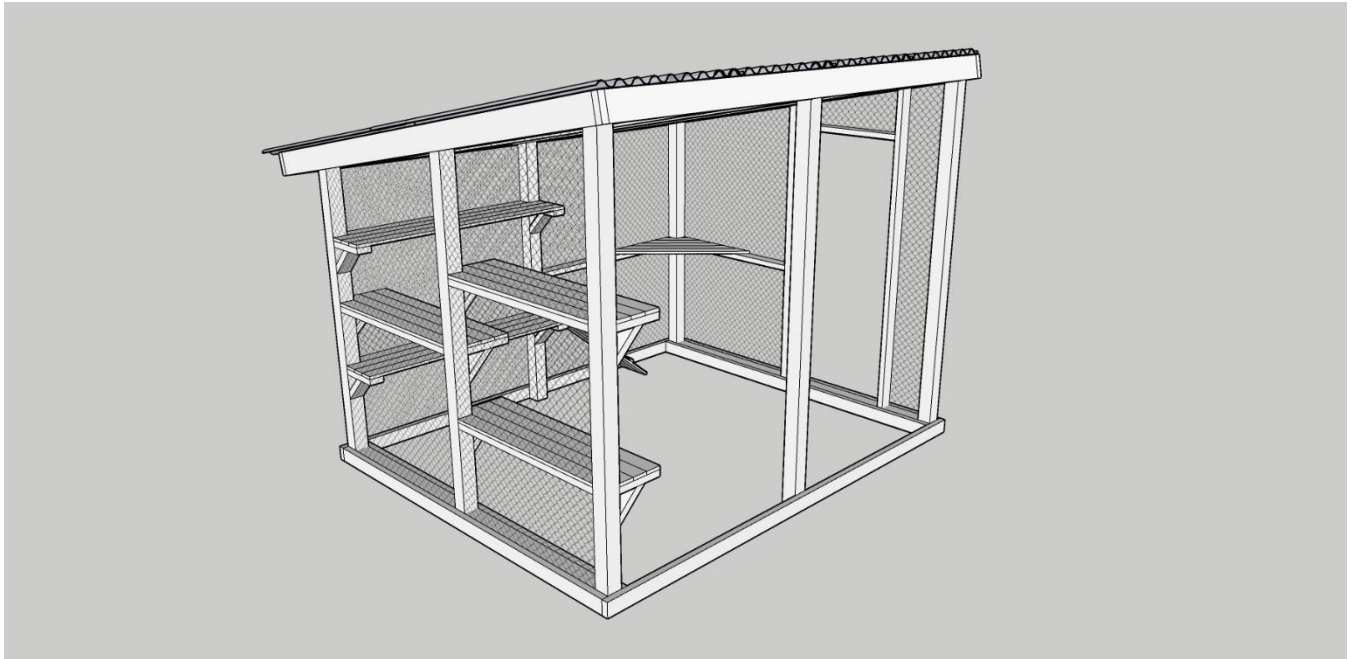

STEP 17

2 pieces of 2×4 lumber – 30" long

2 pieces of 2×4 lumber – 68" long

1 piece of 2×4 lumber – 27" long

2 piece of 2×4 lumber – 43" long. cut corners at 45 degrees

Next, build the door frame from 4×2 lumber. Drill pilot holes and insert 3 1/2" screws to lock the frame together tightly

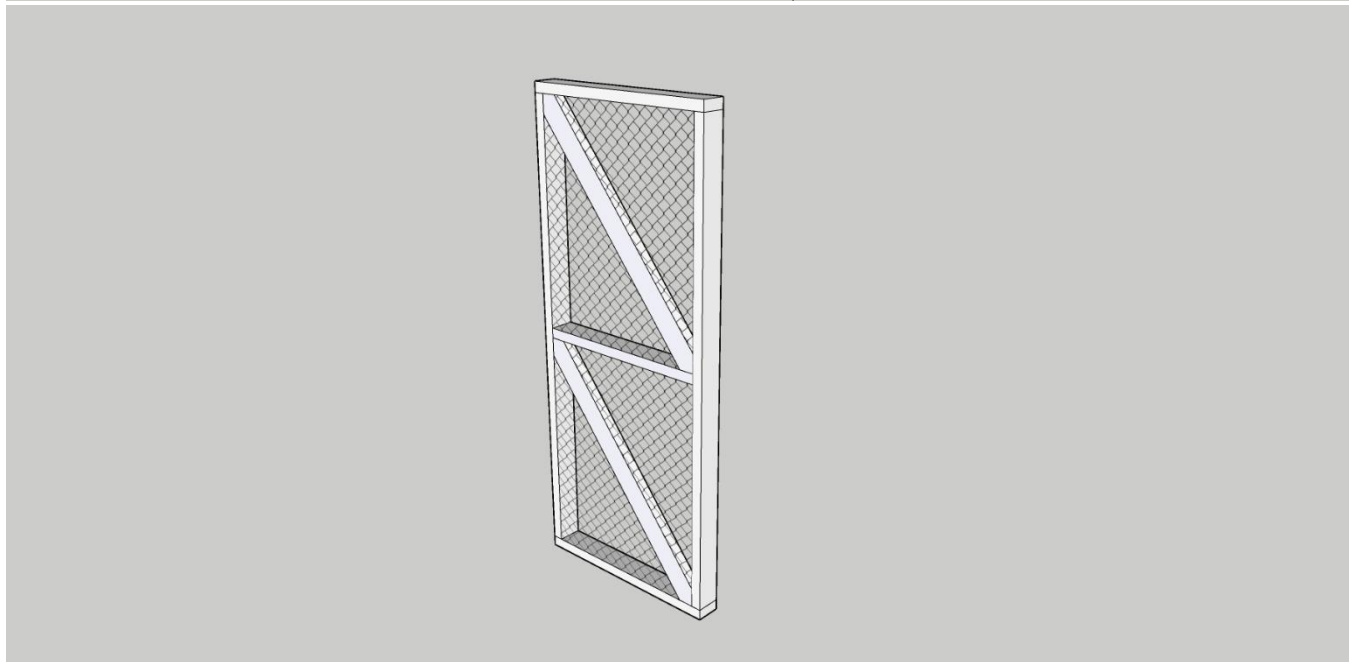
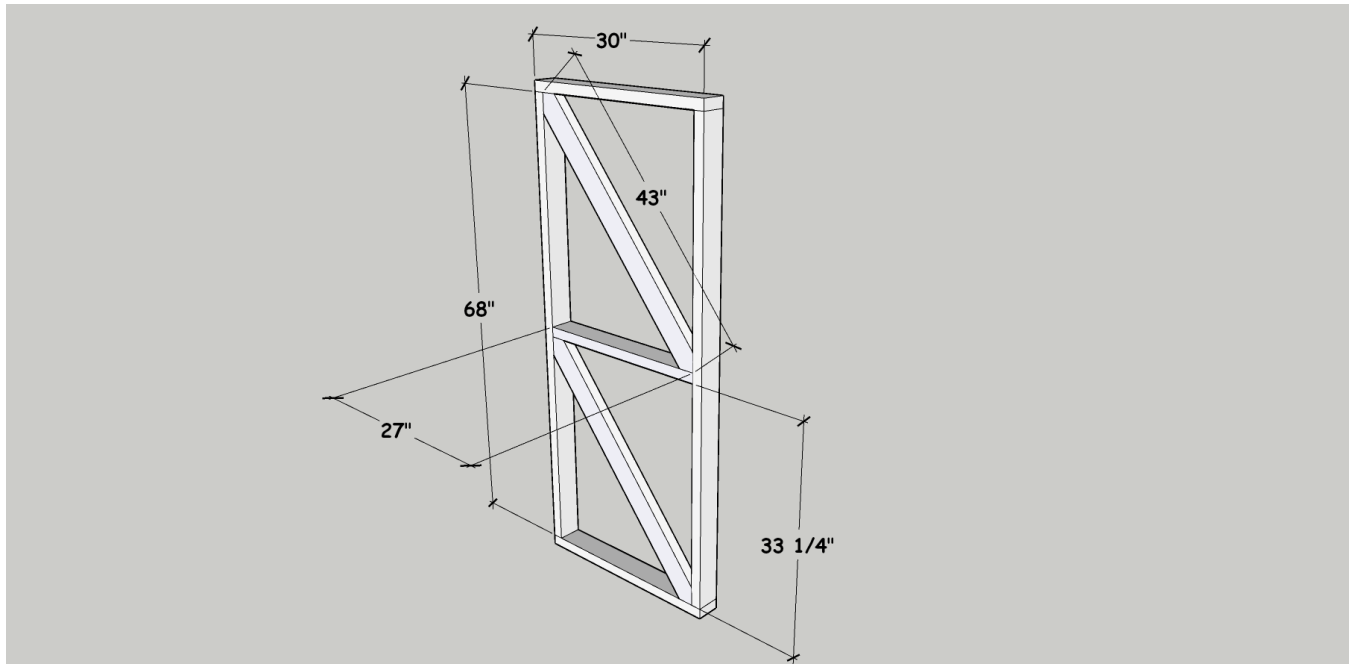

STEP 18

Fit the door into place and then secure it to the frame with hinges. Make sure the door opens and closes properly and install a latch, so you can lock it into place tightly.

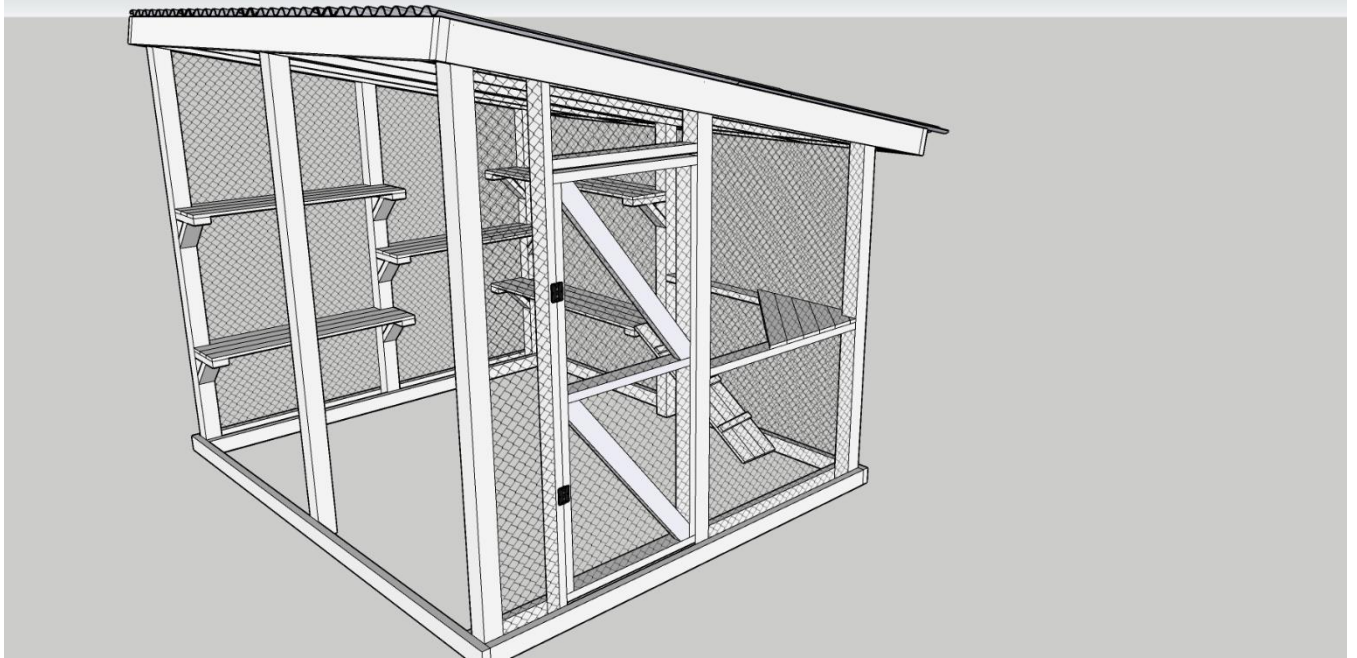

STEP 19

Once you are done building the catio, you need to take care of the finishing touches. Smooth the edges and make sure there are no protruding corners, wires or nails. Apply a few coats of paint to the frame of the catio, if you didn't use cedar or other weather resistant lumber.

Your CATIO

structure should look like the diagram below when this step is finished

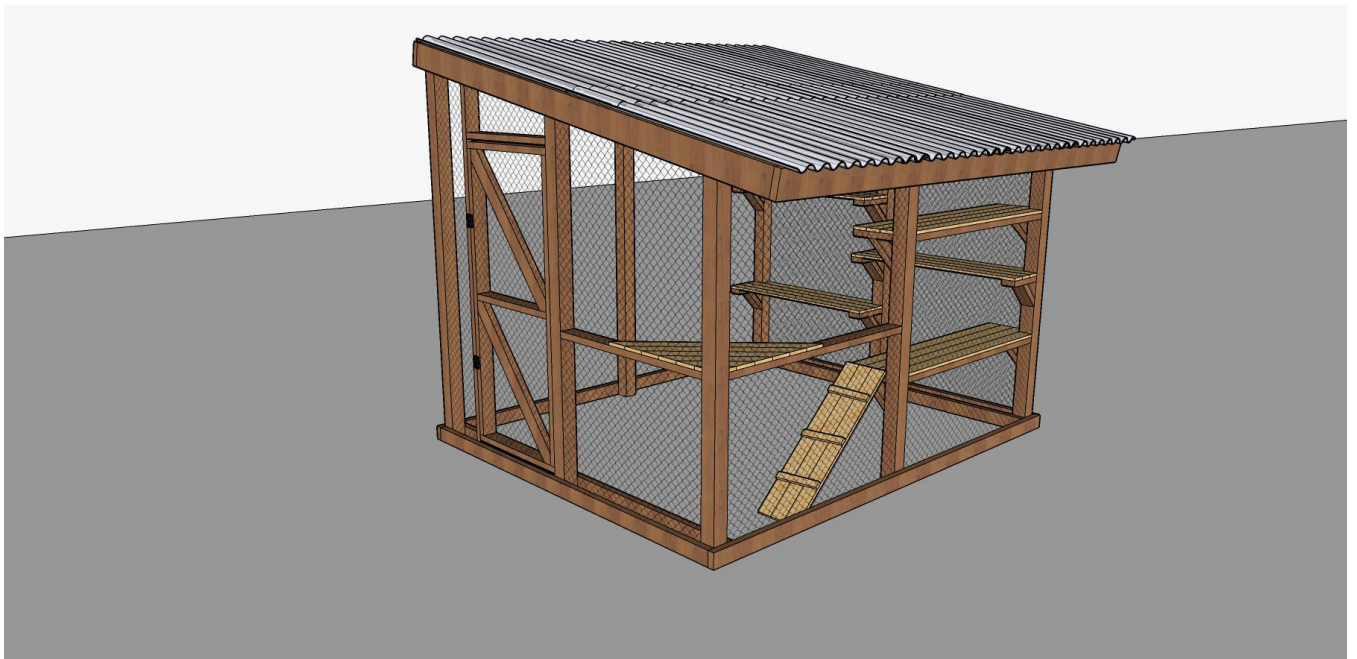

Thank you so much for your purchase!
Please consider leaving a review--it would
be much appreciated.

Happy Working.



Contact: